

## Modulöversikt – Rullbanor

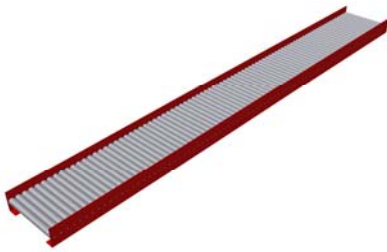

S50 – Rullbana, odreven.  
Rulldiam. 32 mm. Rulldelning  
34 mm



AX100 – Rullbana, odreven  
Typ AO \*



AX100 – Rullbana, odreven. Låga  
spant i änden



AX100 – Rullbana, odreven.  
Flyttbar på hjul, med handtag och  
manuellt fällbart stopp

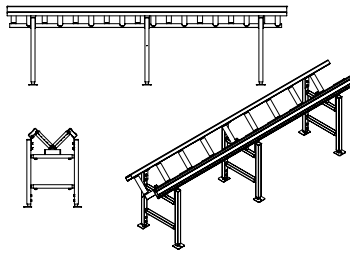

AX100 – Rullbana, odreven med  
rullar i 90°



AX100 - Hjulbana



AX100 – Rullbana, driven  
ackumulerande Typ AX.  
Axeldriven \*

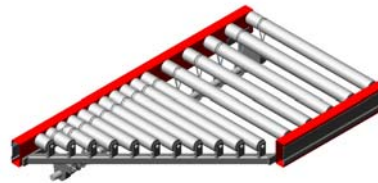

AX100 – Vinkelanslutning 45°  
Typ VA \*



AX100 – Grind, driven/odreven  
Typ DG/OG \*

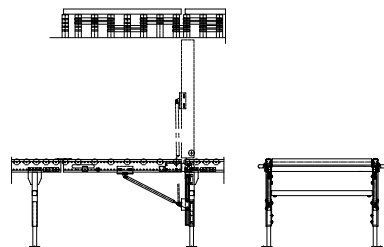

AX100 – Grind, rulle till rulle drift

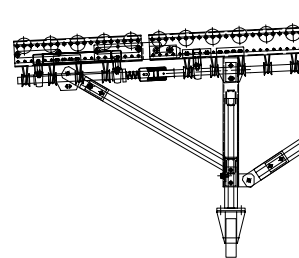

AX100 – Avtagbar rullbanedel



AX100 – Rullbana med delade  
rullar

\* Datablad finns

## Modulöversikt – Rullbanor

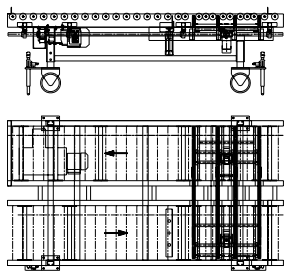

AX100 – Flyttbar robotmodul med fixering



FR100 – Rullbana, driven ackumulerande TYP FR. Flatremsdriven \*

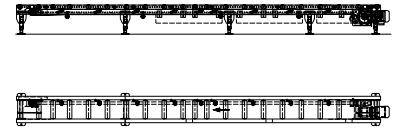

FR100 - Rullbana, driven ackumulerande. Flatremsdriven. Rulllängd 200 mm

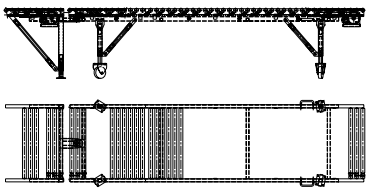

FR100 – Vridbar rullbana

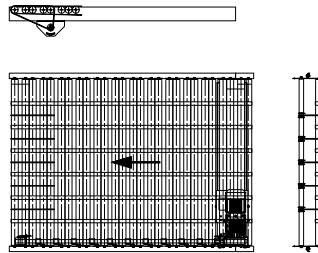

FR100 – Rullbana med rem över rullarna



KR100 – Rullbana, fast driven/driven ackumulerande. Kuggremsdriven



KE100 – Rullbana, fast driven. Kedjedriven

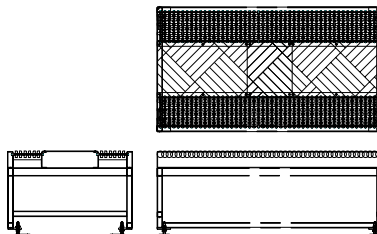

Hjulbana



KE500 – Rullbana, fast driven/driven ackumulerande. Kedjedriven

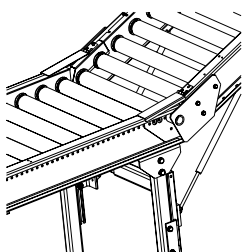

KE500 – Grind, driven



PA1500 – Rullbana, odreven Typ OD \*



PA1500 - Rullist

\* Datablad finns

## Modulöversikt - Rullbanor

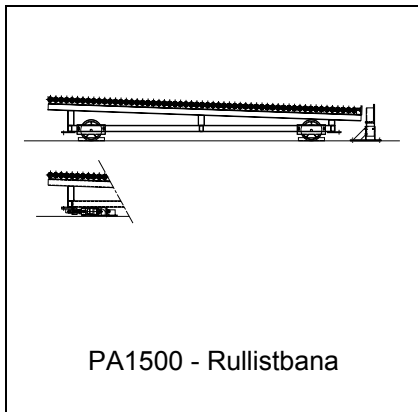

PA1500 - Rullistbana

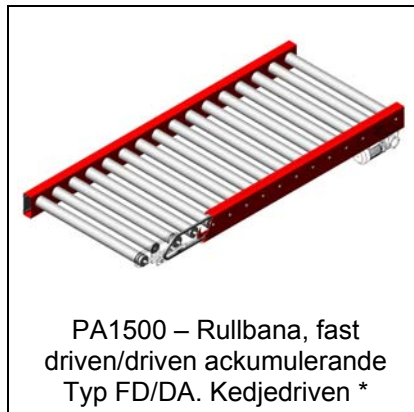

PA1500 – Rullbana, fast driven/driven ackumulerande Typ FD/DA. Kedjedriven \*

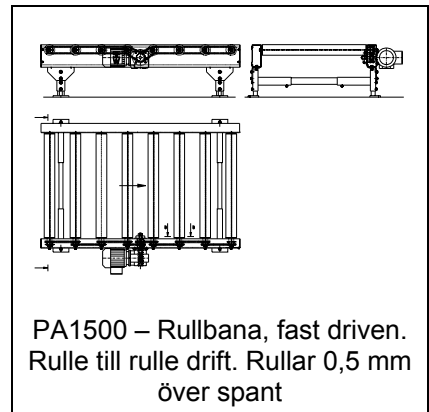

PA1500 – Rullbana, fast driven. Rulle till rulle drift. Rullar 0,5 mm över spant

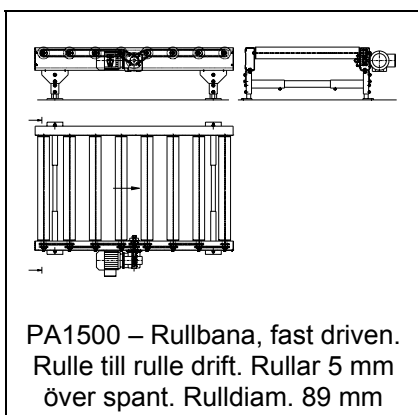

PA1500 – Rullbana, fast driven. Rulle till rulle drift. Rullar 5 mm över spant. Rulldiam. 89 mm

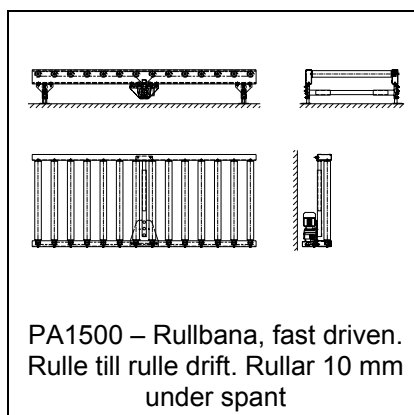

PA1500 – Rullbana, fast driven. Rulle till rulle drift. Rullar 10 mm under spant

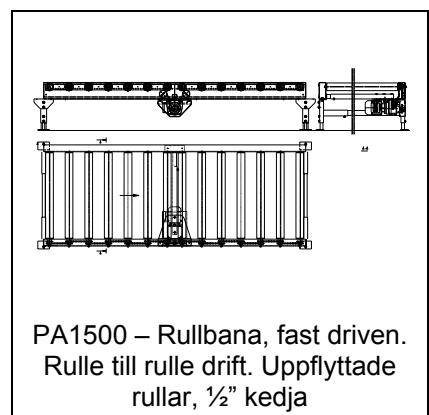

PA1500 – Rullbana, fast driven. Rulle till rulle drift. Uppflyttade rullar, 1/2" kedja

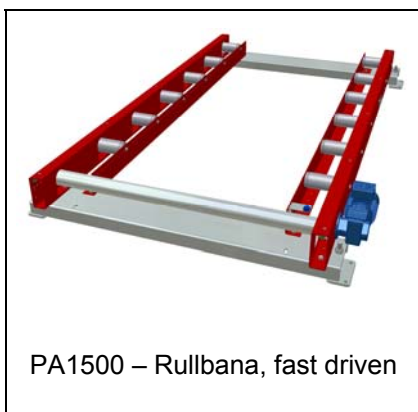

PA1500 – Rullbana, fast driven



PA1500 Rostfritt – Rullbana, fast driven. Kedjedriven

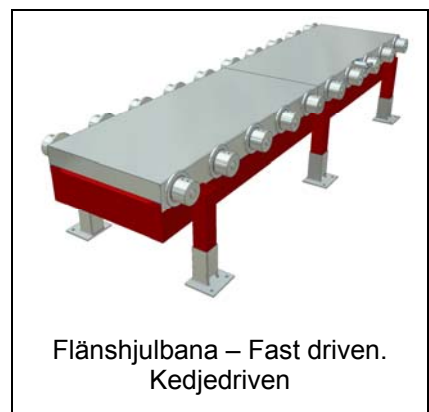

Flänshjulbana – Fast driven. Kedjedriven

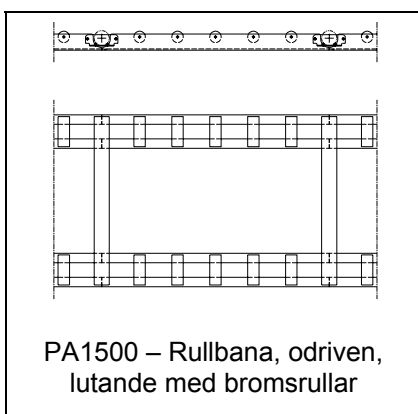

PA1500 – Rullbana, odriven, lutande med bromsrullar

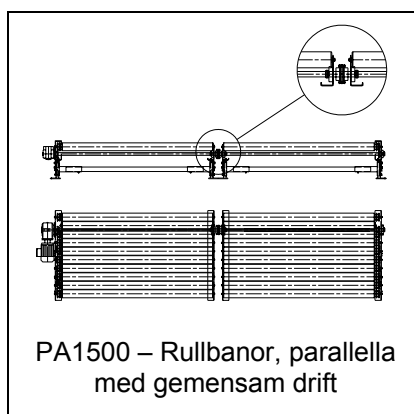

PA1500 – Rullbanor, parallella med gemensam drift



AX100 Rostfritt – Rullbana, driven ackumulerande. Axeldriven. Elektrogalv. rullar

\* Datablad finns

## Modulöversikt - Rullbanor



FR100 – Vinkelanslutning 45°



FR100 – Uppfällbar rullbana



KE100 – Uppfällbar rullbana

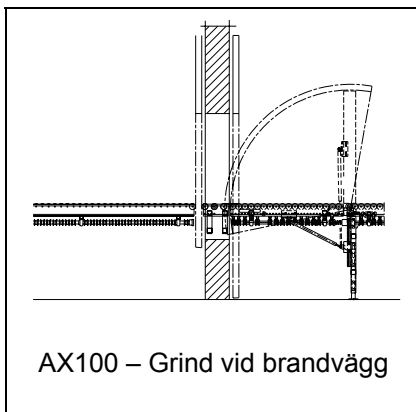

AX100 – Grind vid brandvägg

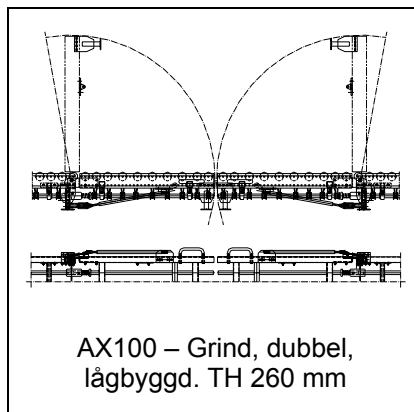

AX100 – Grind, dubbel,  
lågbyggd. TH 260 mm

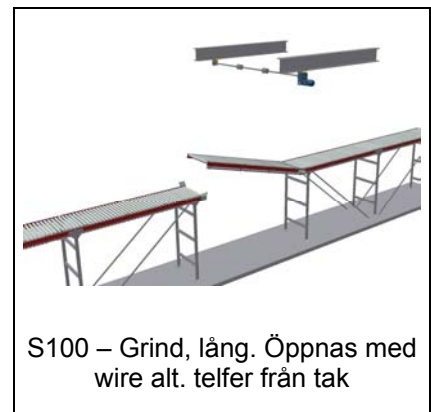

S100 – Grind, lång. Öppnas med  
wire alt. telfer från tak



PA1500 – Rullbana, fast driven.  
Rulle till rulle drift. Rullar 14 mm  
under spant. Rulldiam. 89 mm

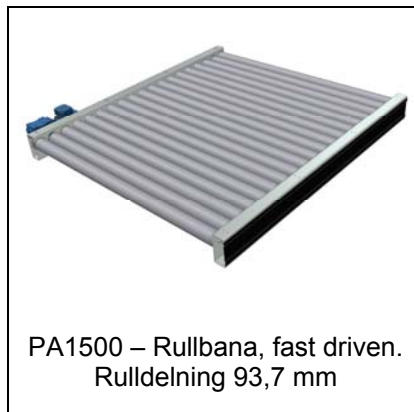

PA1500 – Rullbana, fast driven.  
Rulldelning 93,7 mm

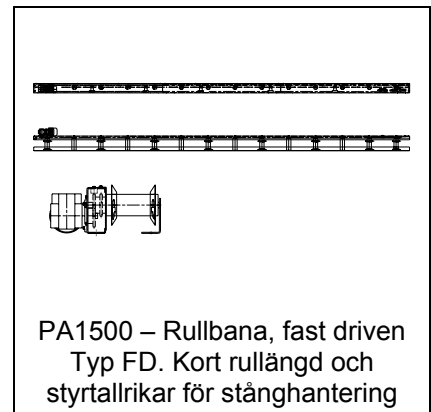

PA1500 – Rullbana, fast driven  
Typ FD. Kort rullängd och  
styrallrikar för stånghantering



AX100 – Rullbana, odriven för  
placering på väg. Rulldiam.  
32 mm

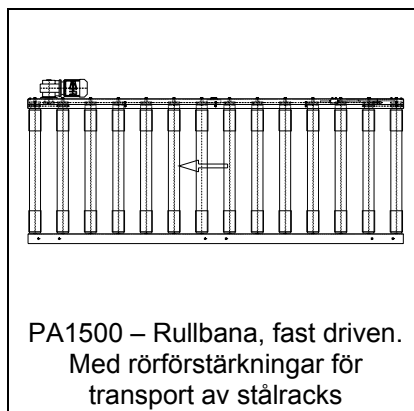

PA1500 – Rullbana, fast driven.  
Med rörförstärkningar för  
transport av stål racks



AX100 – Rullbana, odriven.  
Parallella banor

\* Datablad finns

## Modulöversikt - Rullbanor

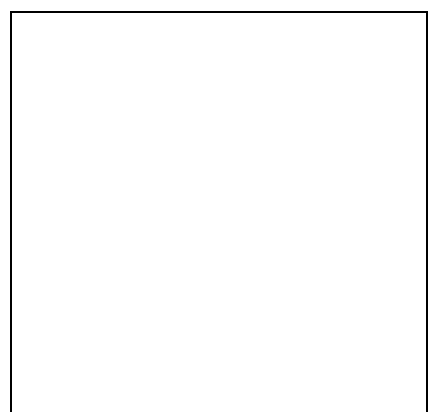
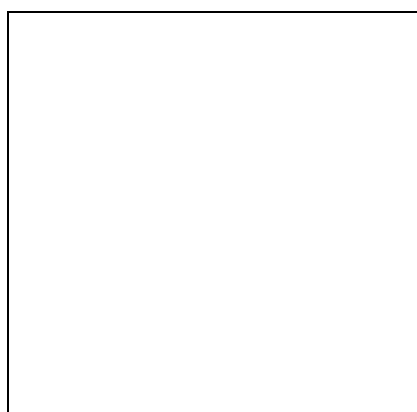
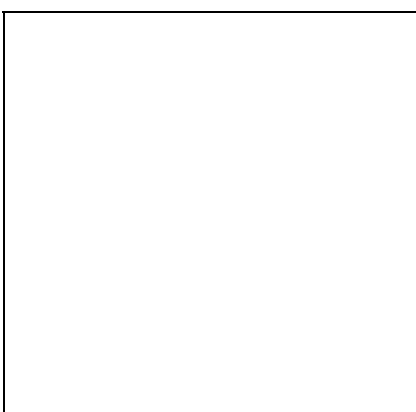
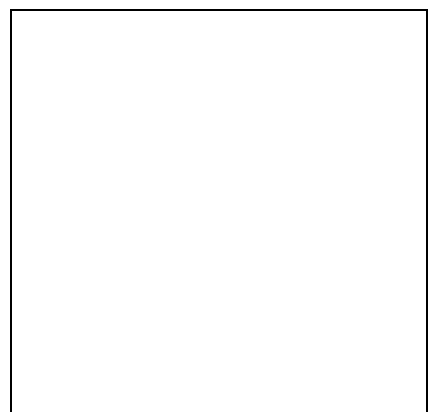
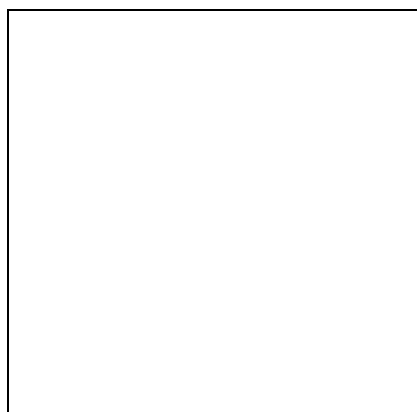
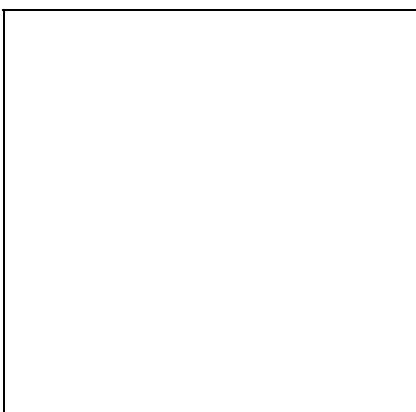
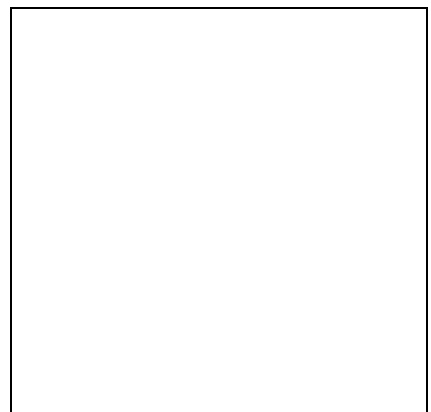
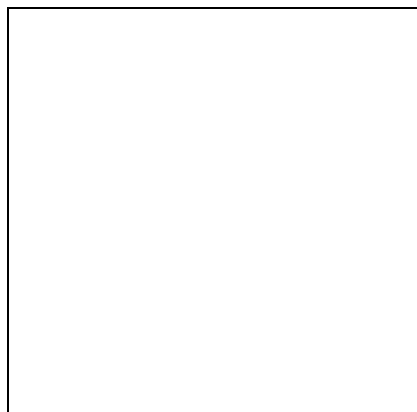
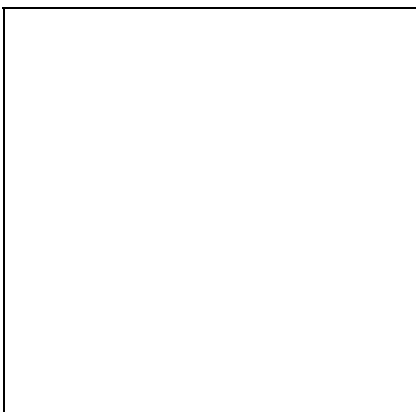
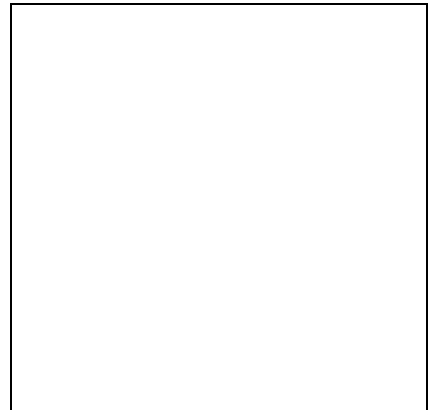
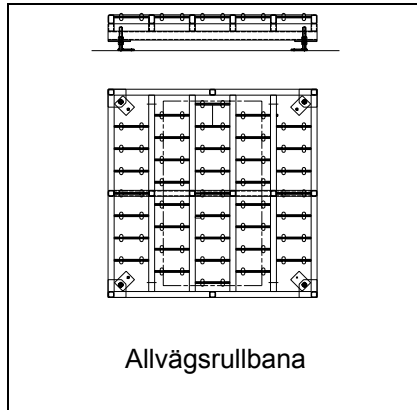
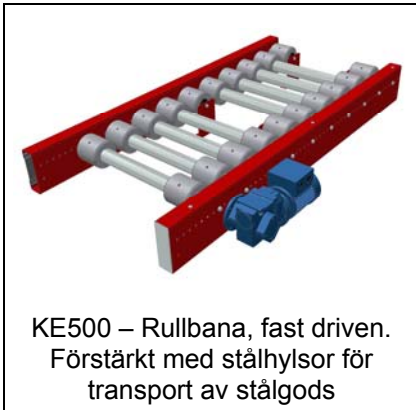

\* Datablad finns